

Hydraulic drive power unit

Low noise compact unit

„Wispering power unit“

RE 51096/04.09
Replaces: 02.06

1/10

Type ABFAG

Component series 2X
Reservoir volume 100-1000 litres
horizontal design

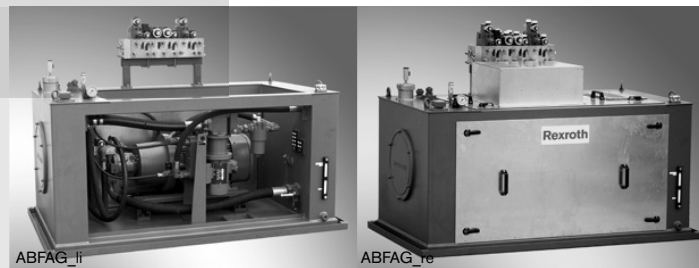

ABFAG_li

Type ABFAG ...open

ABFAG_re

Type ABFAG ...closed

Overview of contents

Contents	Page
Features	1
Ordering details	2
Function	2
Circuit	3
Technical data	4
Selection table	5
Typical noise values	6
Replacement filter elements	6
Float switch settings	7
Connection sizes for flanges and fittings	7
Unit dimensions	8
Pulsation damper, drip tray to the WHG (Water Protection Act)	9
Engineering and commissioning guidelines	10

Features

- Very low noise compact unit
- Areas of application:
 - General machinery
 - Plastic processing machines
 - Stroke and lifting systems
 - Presses
 - Laboratory, schools
- The reservoir is in the form of a U with a flexibly mounted motor pump assembly
- The actuator connections terminate at a flexibly mounted bulk-head panel
- Good air separation characteristics
- Separate filter/cooler circuit
- Very accessible

Ordering details

ABFAG		S	2X	/	W	T	M
Standard power unit type ABFAG	= ABFAG						M =
Reservoir volume 100 litres	= 0100						NBR seals (other seals on request) ⚠ Attention! The compatibility of the seals and pressure fluid has to be taken into account!
Reservoir volume 250 litres	= 0250					T =	
Reservoir volume 630 litres	= 0630					With thermostat	
Reservoir volume 1000 litres	= 1000					W =	
Material Steel		= S					With oil/water cooler
Component series 20 to 29 (20 to 29: unchanged installation and connection dimensions)			= 2X				Electric motor frame size E.g. 180M-4-B0 (see page 5)
Pump type							
			= A10VSO18				
			= A10VSO28				
			= A10VSO45				
			= A10VSO71				
			= A10VS100				
			= A10VS140				

Ordering example:
ABFAG-0250S-2X/A10VSO28-180M-4-B0/WTM

Function

Design

The oil reservoir is designed in the form of a 'U' within which the motor pump assembly is located. The motor pump assembly is mounted on anti-vibration mounts. Due to the excellent isolation of structure-borne noise using optimised anti-vibration mounts, the reservoir walls are subjected to very little vibration so that the noise emission from the unit is very low. Noise damping panels are fitted, one on the top and one on the side of the unit, these also contribute to the unusually low noise values. They also make the drive unit very accessible.

General guidelines:

- The actuator connections terminate at a flexibly mounted bulkhead panel.
- The enlarged wall surfaces ensure that any entrapped air easily separates from the pressure fluid.

Mounting controls

Space is foreseen on the rear and the reservoir top for mounting additional controls. Space for mounting accessories, e.g. hydraulic accumulators, etc., is provided on the rear and sides of the unit.

Cooling

Heat generated by the power components of the unit is dissipated via an oil/water cooler.

The cooler is integrated into a separate filter cooler circuit which provides continuous off-line filtration and cooling.

Circuit: U form whisper power unit

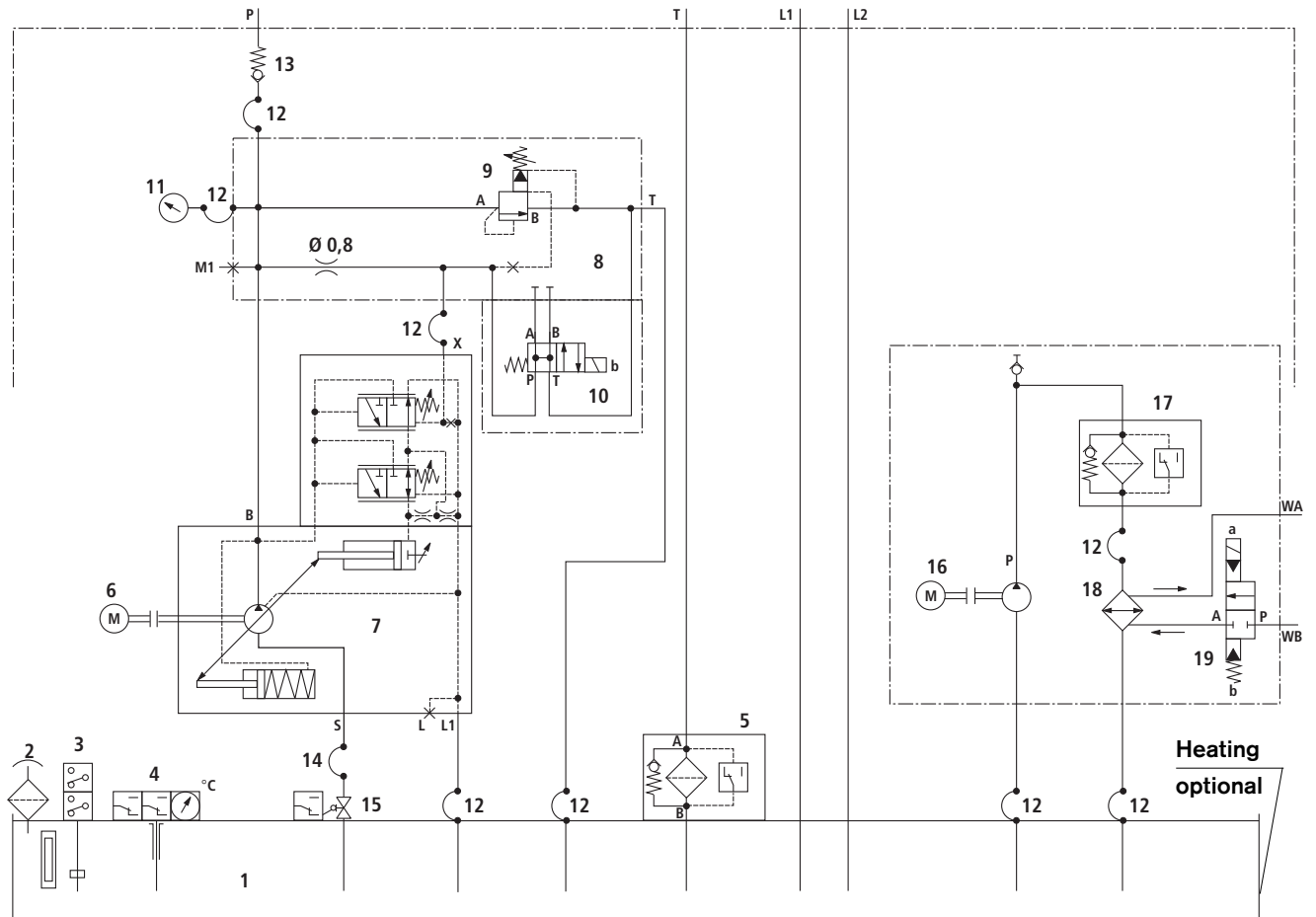

- | | |
|---------------------------|---|
| 1 Oil reservoir | 11 Pressure gauge |
| 2 Filler/breather | 12 Pressure hose |
| 3 Float switch | 13 Check valve |
| 4 Thermostat with display | 14 Suction hose |
| 5 Return filter | 15 Check flap with monitoring of the position |
| 6 Electric motor | 16 Motor pump assembly |
| 7 Axial piston pump | 17 Filter |
| 8 Pressure safety block | 18 Oil/water cooler |
| 9 Pressure relief valve | 19 Water control valve, electric |
| 10 Directional valve | |

Technical data (for applications outside these parameters, please consult us!)

Connections	– Oil		Pipe threads to ISO 1179, pipe connections to DIN 2353/ ISO 8434, flanges to ISO 6162
	– Water		Pipe threads to ISO 228/1
Pump types			A10VSO 18 to catalogue sheet RE 92712
			A10VSO 28 to 140 to catalogue sheet RE 92711
			PVW 18 to 60 to catalogue sheet RE 10335
Motor pump assembly			ABAPG to catalogue sheet RE 51062
Type of pipework			Fittings to DIN 2353; light/heavy series; Type Walform
Pressure fluid			Mineral oil (HL, HLP) to DIN 51524; Fast bio-degradable pressure fluids to VDMA 24 568 (also see RE 90221); HETG (rape seed oil); HEPG (polyglycols); HEES (syntetic ester); Other pressure fluids on request. Please take our specifications stated within catalogue sheet RE 07075 into account.
Pressure fluid temperature range		°C	0 to + 80 The optimim power unit operating temperature using mineral oil HLP to DIN 51 524 lies between 40 and 50 °C. For continuous operation the operating temperature should not exceed 70 °C.
Pressure safety			Pump safety valve to catalogue sheet RE 25890 for the variable displacement pump type A10VSO
Cooling medium			Drinking, industrial, stream and river water
Motor voltage/frequency			400/690 V-D/Y-50 Hz; 460 V-D-60 Hz (other voltages on request); frame type B 35
Direction of rotation			Clockwise
Water control valve			Electrically operated 2/2-way water control valve to AB-E 21-23
Viscosity range	– Optimum	mm ² /s	16 to 36
	– Briefly	mm ² /s	10 to 1000 (also see RE 92711; 92712 and RE 10335)
Cleanliness classes in accordance with ISO code			Max. permissible degree of contamination of the hydraulic fluid to ISO 4406 (c) class 21/18/15 ¹⁾
Surface protection	– 1st under coat		All steel components with zinc dust paint
	– 2nd under coat		Epoxy under coat RAL 5010 (RN 123.01)

¹⁾ The cleanliness classes specified for components must be adhered to in hydraulic systems. Effective filtration prevents malfunction and, at the same time, increases the service life of components.

For the selection of filters, see data sheets RE 50070, RE 50076, RE 50081, RE 50086 and RE 50088.

Selection table

The Material No. can be determined after the pump type, nominal size and nominal pressure has been defined.

The Material No. contains all of the components shown in the circuit.

Reservoir volume 100 litres (filling capacity 130 ltrs.)

Pump nom. size	$q_{V \max}$ in l/min	p_{\max} in bar	Power P in kW	E-motor frame size	Cooling cap. in kW	Material Number
A10VSO 18	26	145	7.5	132M-4-B1	4	R900244959

Reservoir volume 250 litres

Pump nom. size	$q_{V \max}$ in l/min	p_{\max} in bar	Power P in kW	E-motor frame size	Cooling cap. in kW	Material Number
A10VSO 28	39	135	11	160M-4-B0	4	R900772815
	39	190	15	160L-4-B1	4	R900244978
	39	230	18.5	180M-4-B0	7.5	R900244979
	39	280	22	180L-4-B1	7.5	R900244980
A10VSO 45	63	115	15	160L-4-B1	7.5	R900772816
	63	145	18.5	180M-4-B0	7.5	R900244981
	63	170	22	180L-4-B1	7.5	R900244982
	63	235	30	200L-4-B0	15	R900244983

Reservoir volume 630 litres

Pump nom. size	$q_{V \max}$ in l/min	p_{\max} in bar	Power P in kW	E-motor frame size	Cooling cap. in kW	Material Number
A10VSO 71	100	90	18.5	180M-4-B0	7.5	R900772817
	100	110	22	180L-4-B1	7.5	R900772818
	100	150	30	200L-4-B0	15	R900244984
	100	185	37	225S-4-B0	15	R900244985
	100	225	45	225M-4-B1	15	R900244986
A10VSO 100	145	100	30	200L-4-B0	15	R900772819
	145	125	37	225S-4-B0	15	R900772820
	145	160	45	225M-4-B1	15	R900244987
	145	195	55	250M-4-B0	30	R900244988
	145	265	75	280S-4-B0	30	R900244989

Reservoir volume 1000 litres

Pump nom. size	$q_{V \max}$ in l/min	p_{\max} in bar	Power P in kW	E-motor frame size	Cooling cap. in kW	Material Number
A10VSO 140	203	110	45	225M-4-B1	15	R900772821
	203	140	55	250M-4-B0	30	R900244993
	203	190	75	280S-4-B0	30	R900244994
	203	220	90	280M-4-B1	30	R900244995

Typical noise values (measured at $n = 1450 \text{ min}^{-1}$, $\vartheta_{\text{oil}} = 50 \text{ °C}$) Details in dB(A)

Pump type	Pressure in bar	Flow ls/min	Pump nominal size					
			18	28	45	71	100	140
A10VSO	100	$q_{V\text{min}}$	59	60	62	65	68	69
		$q_{V\text{max}}$	62	63	65	68	70	71
	200	$q_{V\text{min}}$	61	63	65	68	71	72
		$q_{V\text{max}}$	64	65	68	71	73	75
	300	$q_{V\text{min}}$	63	66	69	71	72	73
		$q_{V\text{max}}$	66	68	71	73	75	75

Noise pressure level to DIN 45635 part 1, 41;

Distance from noise sensor to power unit; -1m

Measured at $n = 1450 \text{ min}^{-1}$; operating temperature $\vartheta = 50 \text{ °C}$

Pressure fluid: Mineral oil HLP to DIN 51524 part 2

Noise reflections at the place of final use can lead to a higher noise pressure level. (Lower noise levels on request)

With $n = 1000 \text{ min}^{-1}$ the noise values can be reduced by approx. 3 dB(A).

With $n = 1800 \text{ min}^{-1}$ the noise values are increased by approx. 3 dB(A).

When using a drip tray which complies with the WHG (Water Protection Act), the typical noise values increase by approx. 3 dB(A). Built-on controls also increase the noise pressure level!

Replacement filter elements – DIN

Reservoir NS	Pump type	E-motor P in kW	Filter element type for the hydraulic power unit	Material No.	Filter element type for the filter cooler circuit	Material No.
100	A10VSO 18	7.5	ABZFE-R0063-10-1X/M-DIN	R901025291	ABZFE-N0063-10-1X/M-DIN	R901025361
250	A10VSO 28	11; 15	ABZFE-R0100-10-1X/M-DIN	R901025293	ABZFE-N0100-10-1X/M-DIN	R901025362
		18.5; 22				
	A10VSO 45	15 - 22	ABZFE-R0160-10-1X/M-DIN	R901025295	ABZFE-N0160-10-1X/M-DIN	R901025363
		30				
630	A10VSO 71	18.5 - 22	ABZFE-R0250-10-1X/M-DIN	R901025297	ABZFE-N0100-10-1X/M-DIN	R901025362
		30 - 45				
	A10VSO 100	30 - 45	ABZFE-R0400-10-1X/M-DIN	R901025298		
		55 - 75				
1000	A10VSO 140	45				
		55 - 90				

Float switch settings

Reservoir nominal size	Residual volume at the upper switching point in litres	Residual volume at the lower switching point in litres
100	93	69
250	160	145
630	515	455
1000	745	685

Flange and fitting sizes (SAE connections 3000 PSI) (in mm)

Reservoir NS (in ltrs.)	Pump type								
	A10VSO 18			A10VSO 28			A10VSO 45		
	P	T	L	P	T	L	P	T	L
100	Ø16	G1	Ø18						
250				Ø20	G1	Ø18	Ø25	G11/4	Ø18
630									
1000									

Reservoir NS (in ltrs.)	Pump type								
	A10VSO 71			A10VSO 100			A10VSO 140		
	P	T	L	P	T	L	P	T	L
100									
250									
630	Ø30	G11/2	Ø22	Ø38	SAE2	Ø28			
1000							Ø38	SAE2	Ø28

Unit dimensions (in mm)

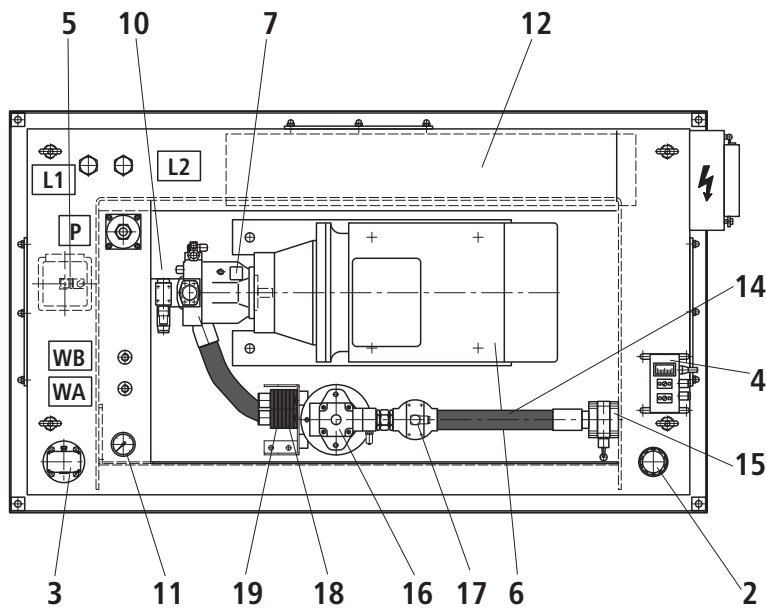
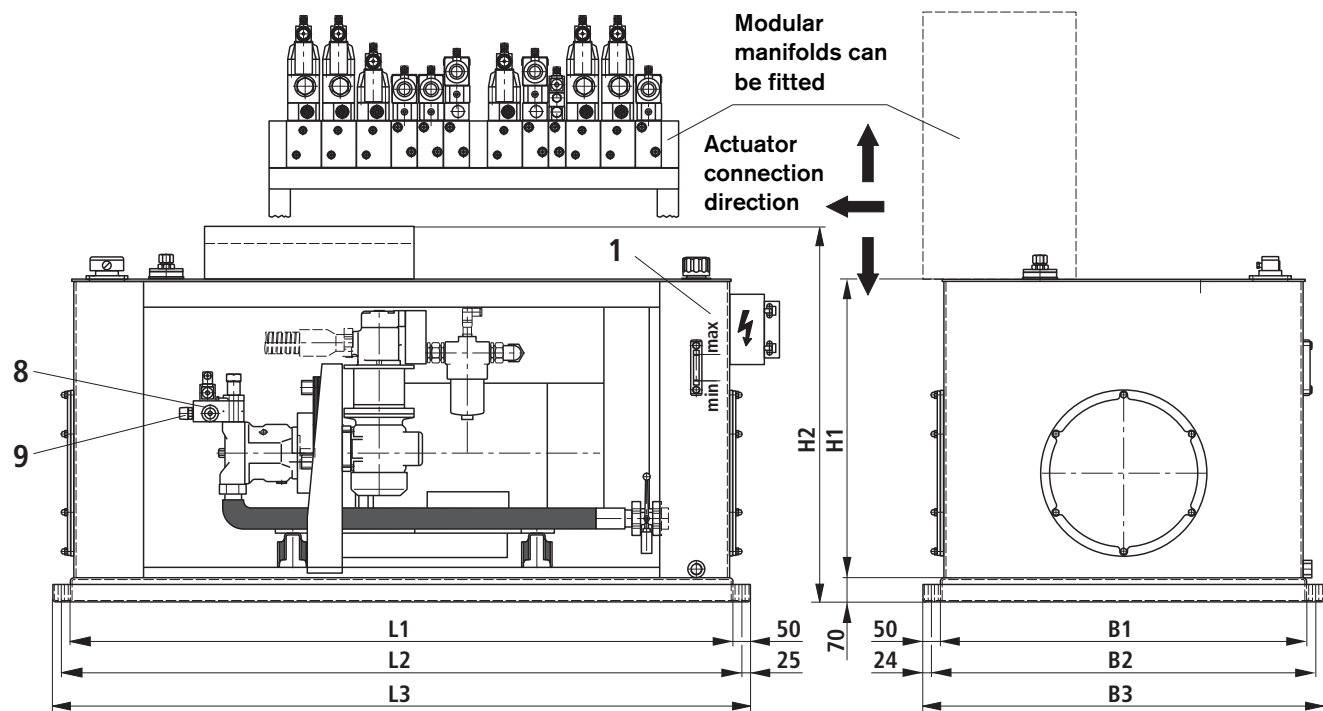

- 1 Oil reservoir
- 2 Filler/breather
- 3 Float switch
- 4 Thermostat with display
- 5 Return filter
- 6 Electric motor
- 7 Axial piston pump
- 8 Pressure safety block
- 9 Pressure relief valve
- 10 Directional valve
- 11 Pressure gauge
- 12 Area for controls
- 13 Check valve (in pipe work)
- 14 Suction hose
- 15 Check flap with monitoring of the position
- 16 Motor pump assembly
- 17 Filter
- 18 Oil/water cooler
- 19 Water control valve, electrical

Reservoir - NS	L1	L2	L3	B1	B2	B3	H1	H2
100	1450	1502	1550	800	852	900	755	1070
250	1850	1902	1950	1000	1052	1100	955	1315
630	2300	2352	2400	1200	1252	1300	1080	1590
1000	2300	2352	2400	1250	1302	1350	1280	1790

Option: Pulsation damper

Pulsation dampers are fitted into hydraulic systems that use displacement pumps and where noise is transmitted via the pressure fluid. Controls that are built onto the unit and their associated pipe work increase the noise values. The nominal values can be retained by using the pulsation damper (see page 6). It is fitted directly onto the pumps pressure connection. For further information see RE 50142.

Pump	Nominal size	Material number
A10VSO	18, 28	R900863597
A10VSO	45, 71	R900863407
A10VSO	100, 140	R900863406

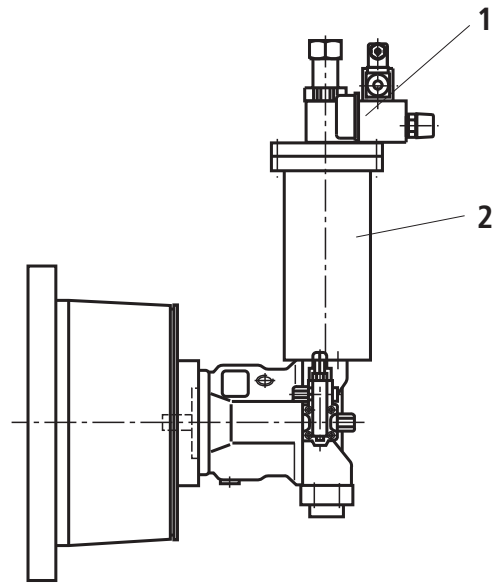

- 1 Pump safety block to RE 25890
- 2 Pulsation damper (max. pressure 300 bar)

Option: Drip tray in accordance with the Water Protection Act (WHG) (in mm)

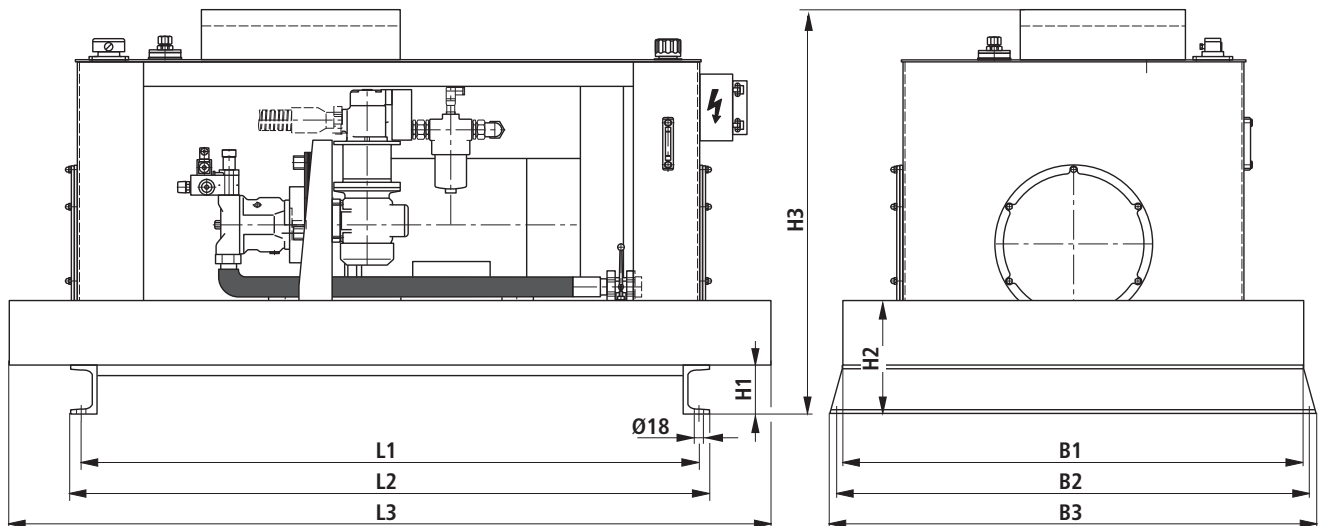

Reservoir - NS	Material No.	L1	L2	L3	B1	B2	B3	H1	H2	H3
100	R900780835	1500	1550	1800	1150	1200	1250	140	260	1215
250	R900780836	1900	1950	2200	1350	1400	1450	140	240	1460
630	R900780837	2350	2400	2650	1550	1600	1650	140	285	1735
1000	R900780838	2350	2400	2650	1600	1650	1700	160	355	1955

When using a drip tray which complies with the WHG (Water Protection Act), the typical noise values increase by approx. 3 dB(A).

Ordering example:

OELWANNE ABFAG 250S 2200 x 1450 x 260
(Material No. **R900780836**)

Engineering guidelines

These units are of a modular design.
For further information please contact your Bosch Rexroth sales office.

Comprehensive instructions and proposals can be found in the Hydraulic Trainer, volume 3, RE 00281, „Planning and design of hydraulic power systems.“

Commissioning guidelines

General

- The power units supplied by ourselves have been tested for function and performance. Changes in any form or manner to the power units are not permitted as this would also invalidate any guarantee claims.
- Repairs may only be carried out by the manufacturer or authorised agent or subsidiary. No guarantee will be accepted for commissioning carried out by third parties.

Commissioning

- Only fill the pressure fluid via a filter which has the necessary retention rate.
- Take into account the direction of rotation arrow when connecting the electric motor.
- Start the pump without load and let it displace oil without pressure for a few seconds in order to provide sufficient lubrication.
- Never run the pump **without** oil.
- If the pump, after approx. 20 seconds, does not displace oil without any bubbles then the system has to be rechecked.
- After the operating values have been reached, check the pipe connections for leakage and check the operating temperature.

Bleeding

- Before commissioning, the pump housing must be filled with oil.

Important guidelines

- Assembly, maintenance and servicing of the power unit must only be carried out by authorised, trained and instructed personnel!
- The power unit must only be operated within the permissible limits!
- When carrying out any work on the power unit, switch the system to zero pressure! Unauthorised conversions and modifications which affect the safety and function are not permitted!
- Provide protective measures and **do not** remove any existing protective devices.
- Ensure that the fixing bolts are correctly fitted! (Take into account the prescribed tightening torque!)
- The general valid safety and accident prevention regulations must be adhered to!
- Reservoir nominal size 100 has to be filled with a minimum of 130 litres (sight glass „max“).

Note: with reference to the EC machinery guidelines 89/392 EWG annex II, section B; manufacturer's declaration:

The supplied assemblies have been manufactured in accordance with the harmonised standards EN 982, EN 983, EN ISO 12100 and DIN EN 60204-1.

Commissioning may not take place until it has been confirmed that the machine, into which the assembly is to be installed, conforms with the regulations stated within the EG guidelines.

Bosch Rexroth AG
Hydraulics
Zum Eisengießer 1
97816 Lohr am Main, Germany
Telefon +49 (0) 93 52 / 18-0
Telefax +49 (0) 93 52 / 18-23 58
documentation@boschrexroth.de
www.boschrexroth.de

© This document, as well as the data, specifications and other information set forth in it, are the exclusive property of Bosch Rexroth AG. It may not be reproduced or given to third parties without its consent.

The data specified above only serve to describe the product. No statements concerning a certain condition or suitability for a certain application can be derived from our information. The information given does not release the user from the obligation of own judgment and verification. It must be remembered that our products are subject to a natural process of wear and aging.